

Handrail Storage

As a general rule handrails do not store well over extended periods of time.

Even under ideal conditions, handrails will continue to age during storage, with sunlight, heat, and humidity accelerating the process. During storage, rubber handrails will often develop a waxy, protective haze. This is normal and by design, as the migration of the protective wax to the surface guards the handrail throughout its lifetime. Simply give the handrails a good cleaning after installation.

Storage Recommendations:

- Store in a dark, cool, and dry environment, with a low relative humidity.
- New handrails are best stored in their original packaging.
- Used handrails should be coiled up according to EHC Handrail Coiling procedures, avoiding excessively tight coils or kinks in the handrails. Once properly coiled, the handrails should be placed in a protective bag or box.
- Handrail containers should be stored flat and not be subjected to added weight or stress imposed by other materials being stacked or stored on top of the handrails.
- Avoid storing in penthouses or elevator pits, as both locations leave the handrail susceptible to high temperatures as well as oil and moisture contamination.
- A handrail can remain in storage for approximately 3-4 years. Handrail stored for this length of time, however, may not perform for a full service life compared to a new handrail from the factory.
- The surface of a stored handrail will require cleaning before installation. (See EHC Cleaning & Polishing procedures).

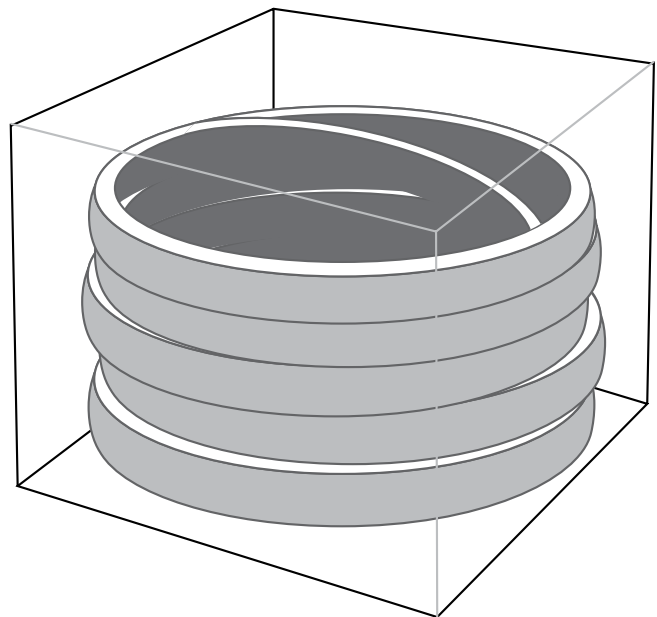

Important Reminder

After storage, uncoil handrail and let it “relax” in that state for at least 24 hours before installing on the escalator.